**SERVICE BULLETIN**

SB No.

144

Issue No.

1

TITLE

TRIM TAB DRIVE PIN CHECK

CLASSIFICATION

This Service Bulletin has been classified by SAL as Essential

COMPLIANCE

Within next 10 flying hours

APPLICABILITY:

T67M260, T67M260-T3A.

INTRODUCTION

It has been reported that a trim tab drive pin of incorrect dimensions was fitted to an aircraft, in accordance with an incorrect entry in the Illustrated Parts Catalogue for the T67M260 and T67M260-T3A aircraft.

This Service Bulletin requires a one time inspection and, if applicable, correction.

ACTION:

1. Locate elevator trim tab on port side of the elevator.
2. Measure dimension as indicated on Fig. 1.
3. The dimension on the correct trim tab drive pin (SAL Pt No. T67G-31-501) is 34.5mm. Incorrect drive pin (SAL Pt No. T67B-31-529) has a dimension of 44.5mm.
4. If Pt No. T67B-31-529 is found to be fitted, it should be replaced with T67G-31-501.
5. If replacement is required, when fitting correct trim tab drive pin (Pt No. T67G-31-501) screw up tight against lower surface of trim tab. To ensure correct alignment of drive pin, use either shim washer (SAL Pt No. T67B-51-533), washer (Pt No. 126-23-104) or thin washer (Pt No. 126-23-711) or any combination up to 2 washers and 1 shim washer. Use Loctite 636 on threads.
6. Ensure correct movements and operation of trim tab and Indicator, in accordance with Maintenance Manual.
7. IPC will be corrected at next amendment.
8. Annotate logbook "SB 144 complied with".

ISSUED BY:



Date

12-2-98

for and on behalf of **SLINGSBY AVIATION LIMITED**
Kirkbymoorside, York YO6 6EZ, EnglandTel. 01751 432474
Fax 01751 431173

Page

1

of

2

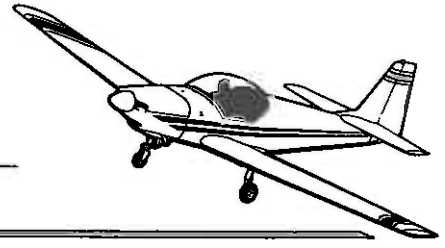

SERVICE BULLETIN

SB No.

144

Issue No.

1

TITLE

TRIM TAB DRIVE PIN CHECK

CONTINUED

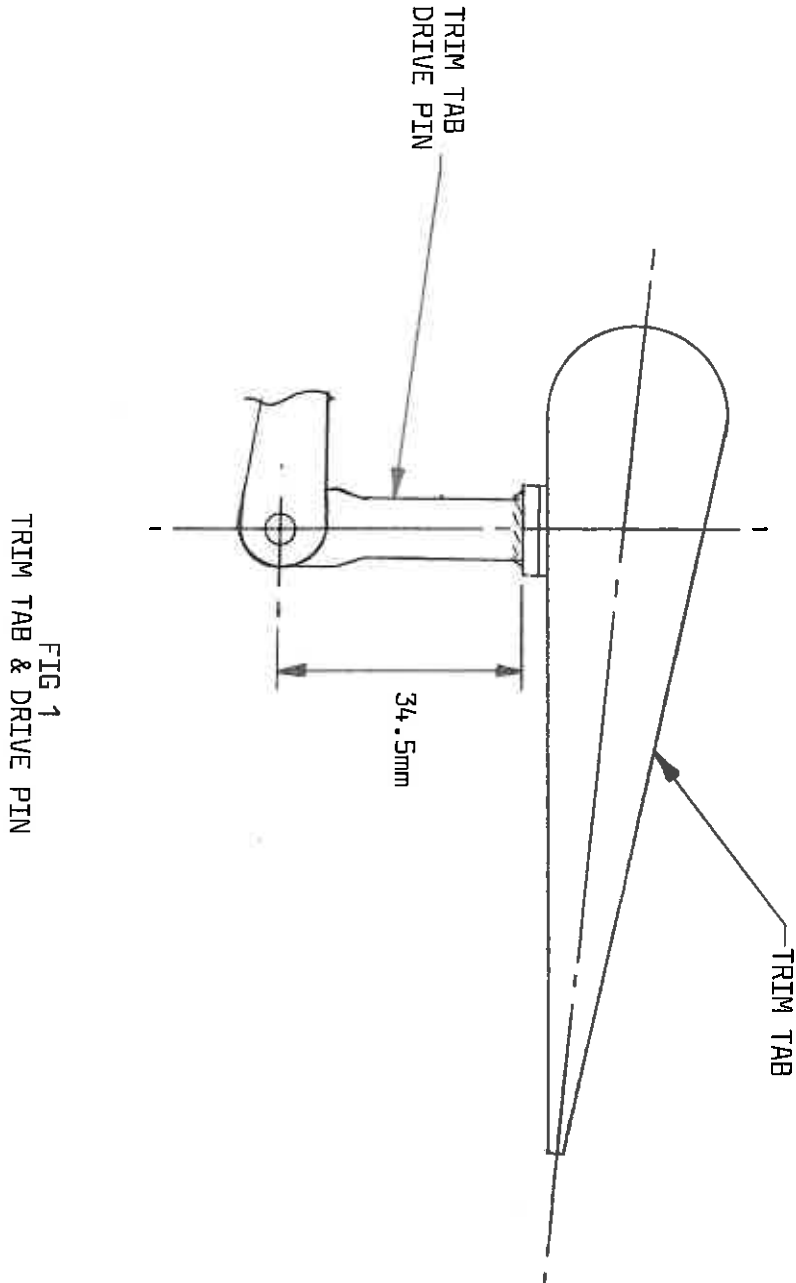

Approved:

A handwritten signature in black ink, appearing to be 'J. J. J.', written over a horizontal line.

Date:

12-2-93

Page

2

of

2