

SERVICE BULLETIN

 SB No. 139^a Issue No. 1

TITLE INSPECTION OF STEERING ARM ON FAIREY HYDRAULICS NOSE LEG

CLASSIFICATION

This Service Bulletin has been classified by the CAA as Mandatory

COMPLIANCE

 Inspection within 25 flying hours.
 If no cracks found, inspect every 150 flying hours

APPLICABILITY:

T67M260 and T67M260-T3A. Post Mod M468 T67C and T67M-MkII and Post Mod M791 T67M-MkII.

Attached is Fairey Hydraulics Service Bulletin No. 32-16 Issue 1 "Nose Landing Gear Assembly 5009H1"

Any further information or components required to comply with this Bulletin should be obtained from SAL Product Support Department.

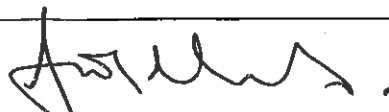
ISSUED BY:

Date 12 - 9 - 97

for and on behalf of

 SLINGSBY AVIATION LIMITED
 Kirkbymoorside, York YO6 6EZ, England Tel 0751 32474 Telex 57597

Page

1 of 1

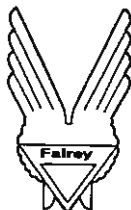

SERVICE BULLETIN

NUMBER 32-16 ISSUE 1

NOSE LANDING GEAR ASSEMBLY 5009H1

SLINGSBY FIREFLY AIRCRAFT
T67M MKII, T67C, T67M260, T67M260-T3A

Checking for cracks on the steering adaptor

1. Planning Information

A. Effectivity

Firefly T67M MKII, T67C, T67M260, T67M260-T3A Aircraft Nose Landing Gear Assembly Part No 5009H1.

B. Reason

There have been occurrences of minor cracks in the steering adaptor in the following areas (Refer Fig.1 and 2)

- the fillet which joins the integral steering arm and the location ring of the adaptor
- radiating from the holes through which the steering bolt passes

C. Description

Visual inspection of parts on all nose landing gear assemblies in the position indicated in Fig.1 and 2 of this Service Bulletin.



SERVICE BULLETIN

D. Compliance

Immediate inspection of the defined area. If a crack is discovered the continued monitoring of the crack every 25 flying hours or replacement of parts.

E. Approval

This Service Bulletin contains no modification information that revises the approved configuration and therefore does not require governmental or other regulatory approval.

F. Material (cost and availability)

The following parts will be supplied by Fairey Hydraulics as required:

Steering Adaptor Part No 63873-84
Steering Bolt Part No 63965-82

G. Manpower

Disassembly/Assembly	- TBD
Inspection	- 0.75 hours

H. Tooling

As required in AMM
Torch
Mirror
Magnifier
Dye Penetrant to MIL-STD 6866

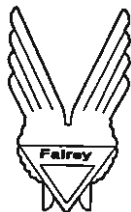

SERVICE BULLETIN

I. Weight and Balance

Not affected.

J. References

Firefly Aircraft Maintenance Manual and Figure 1 and 2 of this bulletin.

2. Accomplishment Instructions

A. Inspection

- (1) Refer to Aircraft Maintenance Manual and remove Nose Landing Gear Assembly from the aircraft. Provided personal and equipment safety is assured the Nose Landing Gear Assembly can be retained and supported in the aircraft while the steering adaptor and bolt are removed for inspection.
- (2) If required clean the steering adaptor (Part No 63873-84) and steering bolt (Part No 63965-82) in accordance with local instructions. Particularly, observe local Health and Safety Instructions in the use of solvents.
- (3) Using a torch, mirror and magnification visually inspect (Refer Fig 1 and 2):
 - the steering adaptor for cracks. Particular attention is to be made to the machined fillet that joins the integral steering arm and the location ring of the adaptor and the area surrounding the holes through which the steering bolt is fitted (internal and external faces)
 - the steering bolt

It is recommended that dye penetrant flaw detection is used.



SERVICE BULLETIN

B. Action/Rectification

(1) No cracks found

- a. Refit Nose Landing Gear Assembly and parts to the aircraft in accordance with the Aircraft Maintenance Manual.

(2) Cracks found

- a. Cracks not exceeding 0.2 in (5.08 mm)

- (1) Refit parts and Nose Landing Gear Assembly to the aircraft in accordance with the Aircraft Maintenance Manual.

- (2) Repeat inspection every 25 flying hours.

- b. Cracks exceeding 0.2 in (5.08 mm)

- (1) Return defective parts to Fairey Hydraulics Ltd.

- (2) Fit new steering adaptor (Part No 63873-84) and steering bolt (Part No 63965-82).



SERVICE BULLETIN

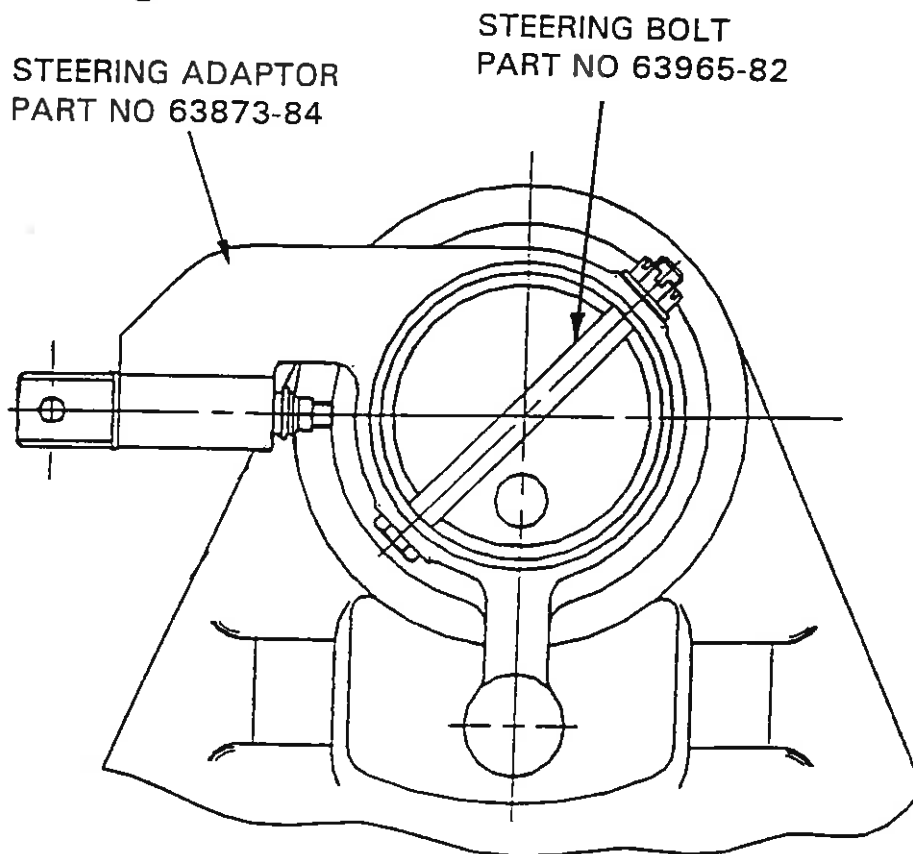
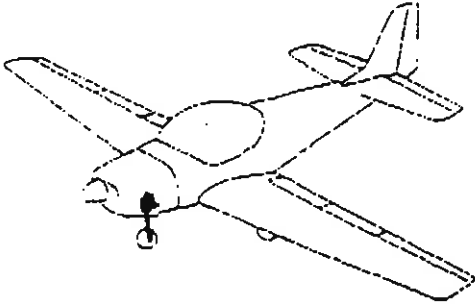
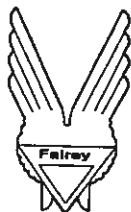

Figure 1 View on top of Nose Landing Gear assembly



SERVICE BULLETIN

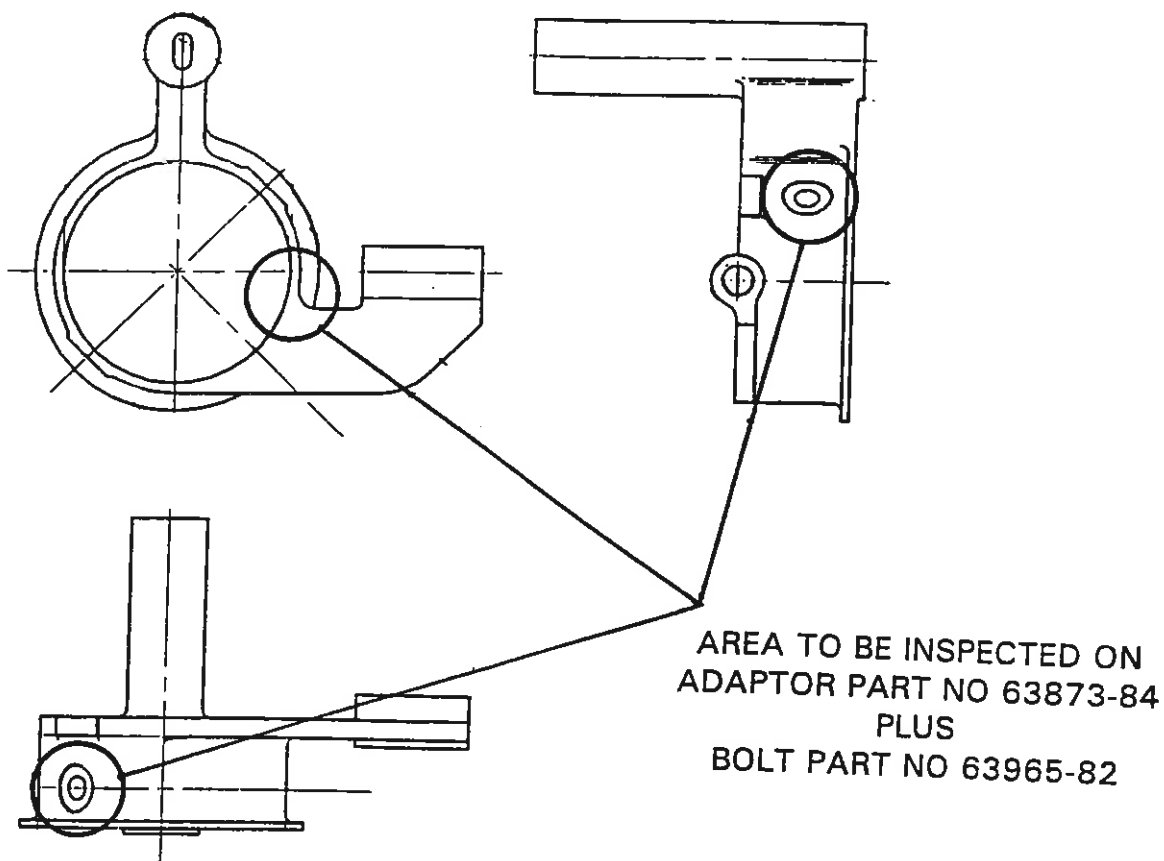

Figure 2 Identification Area