

# SERVICE BULLETIN

SB No. 83 Issue No. 1

**TITLE INSPECTION FOR FOUL BETWEEN NO.2 RUDDER PEDAL PAD PIVOT AND NOSEWHEEL STEERING ROD ARM**

**CLASSIFICATION**

This Service Bulletin has been classified as Mandatory by the CAA

**COMPLIANCE** Before next flight - See also Item 5.

**APPLICABILITY:**

T67B, T67C Series, T67M (Not Works No. 1999), T67M-MkII, T67M200, T67M260 and T67M260-T3A.

**INTRODUCTION:**

Cases have been reported during the build of the T-3A variant of the Firefly, of a potential foul between the No.2 pedal (left hand pilots inbd pedal) inboard pivot bolt tail and head of nosewheel steering rod arm attachment bolt.

This foul is to be found at extreme forward pedal adjustment full rudder deflection.

Additionally a case has been reported of a short bolt having been fitted at the nosewheel steering rod to arm attachment. The consequence of this is that the nut may not be properly locked.

**ACTION**

1. At Position 'A', check that bolt at nosewheel steering rod arm attachment measured 20mm long measured from under head. If not replace with M6 x 20 126-21-050, Ref Fig. 1, orientated as shown.
2. At Position 'B', with No.2 pedal fully adjusted forward and with full right rudder check for clearance between bolt tail and bolt head Ref Fig. 1.

**ISSUED**

20 FEB 1996

ISSUED BY:

*B. Mellen*

Date

16<sup>th</sup> Feb 96

for and on behalf of

SLINGSBY AVIATION LIMITED  
Kirkbymoorside, York YO6 6EZ England

Tel 0751 32474 Telex 57597

Page

1

of

3

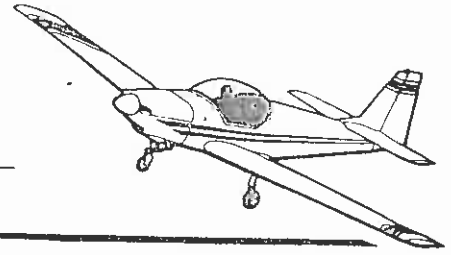
**SERVICE BULLETIN**

SB No. 83 Issue No. 1

TITLE **INSPECTION FOR FOUL BETWEEN NO.2 RUDDER PEDAL PAD PIVOT AND NOSEWHEEL STEERING ROD ARM**

CONTINUED

3. If 1mm or more clearance is shown with pedal mechanism on its stop together with correct rudder deflection with all backlash taken up to minimise the clearance, annotate in Log Book "SB 83 carried out".
4. If clearance is less than 1mm, or touching:
  - i) Replace existing socket head cap screw indicated on Fig. 1. With socket head cap screw 126-21-210 (or T67B-08-981) as shown in Fig. 2. Ensure correct rudder operation and deflections.

The fitting of socket head cap screw 126-21-210 (or T67B-08-981) invokes Mod M671.
  - ii) Annotate aircraft log book "SB 83 carried out" and "Mod M671 incorporated".
5. At each rudder pedal dis-assembly/re-assembly and re-rig, ensure conditions at 2. are met, until Mod M671 at 4 i) is incorporated.

For socket head cap screw 126-21-210 (or T67B-08-981) contact SAL Product Support Department.
6. The Maintenance Manual will be amended to include the above inspections following re-assembly.

Approved:



Date:

16<sup>th</sup> Feb 96

Page

2 of

3

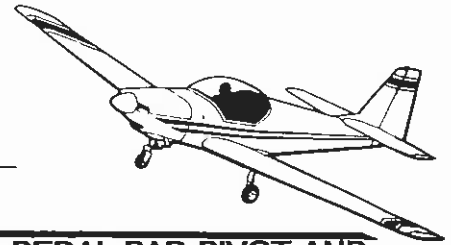

**SERVICE BULLETIN**

SB No. 83 Issue No. 1

TITLE **INSPECTION FOR FOUL BETWEEN NO.2 RUDDER PEDAL PAD PIVOT AND NOSEWHEEL STEERING ROD ARM**

CONTINUED

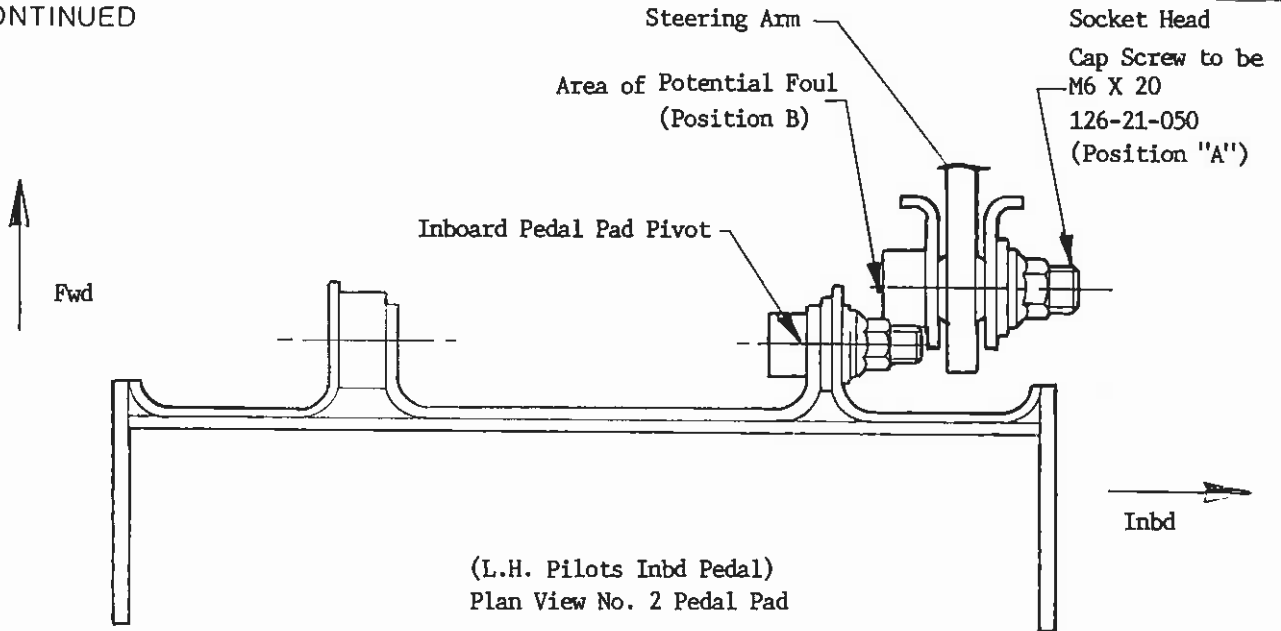
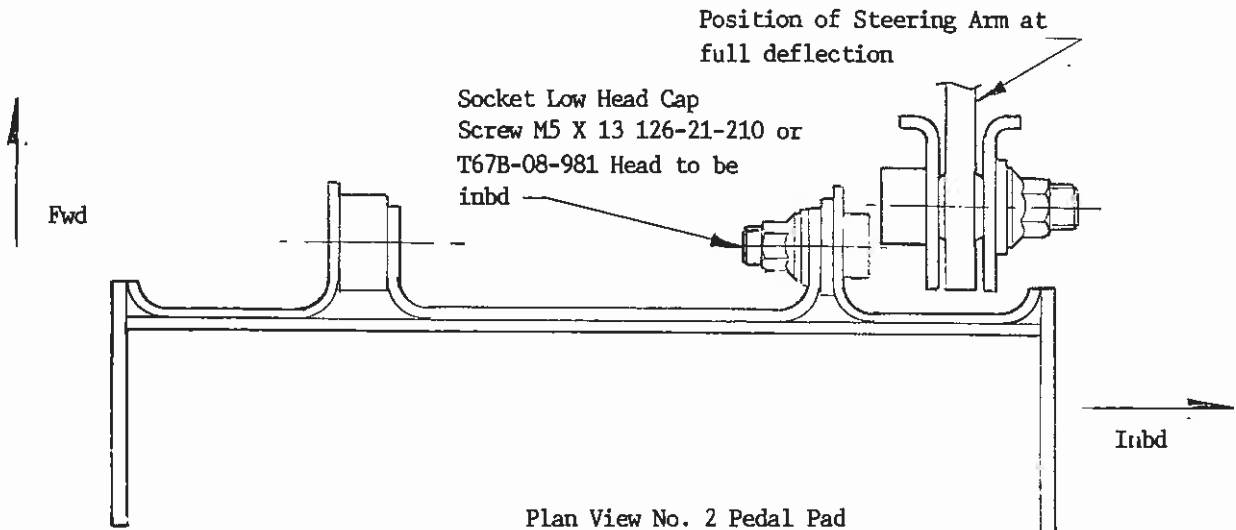

FIG 1



Plan View No. 2 Pedal Pad

FIG 2

Approved:

*B. Meller*

Date: 16<sup>th</sup> Feb 96.

Page

3

of

3