

Service Bulletin

S.B. No: 75

Title: INSPECTION OF RUDDER PEDAL SLIDER/HEATER DISTRIBUTION BOX CLEARANCE

Classification: This Service Bulletin has been classified by SAL as Highly Recommended

Compliance: At next 50 hour check or within one month of receipt of bulletin.
ONLY APPLICABLE IF ISSUE 3 NOT INVOKED/SATISFIED.

Applicability: T67M260 (Works Numbers 2072, 2234 to 2260) and T67M260-T3A (Works Numbers 2109, 2110, 2123 to 2133)

Issue 4: Note "Only applicable" added to Compliance. Works Numbers added to Applicability, extra washer added at para 3.1; at para 3.3.2 part number corrected

INTRODUCTION:

During a post delivery inspection, a foul was discovered between the square rudder pedal slider and the heater distribution box. In addition, the round slider was found to be close to the heater. The foul occurs when the left hand pilot's right hand pedal (Number 2) is adjusted fully forward with full right rudder deflection. Although a foul may occur, there is no possibility of jamming the rudder pedal, only a slight restriction in travel.

ACTION:

1. Check for clearance with No.2 pedal adjusted fully forward, full right rudder, with or without applying the brake.
2. Note clearance, 1mm minimum required between square or round slider ends and heater distribution box with foot loads applied.

If clearance achieved, annotate in Log Book "SB No.75 complied with".

3. If clearance is found to be inadequate, proceed as follows:

- 3.1 Check rudder bar packing is in accordance with the following, Ref. Fig. 1:

At each rudder bar pivot position (4 places) there should be one spacer T67M-45-507 **OR** one off washer 126-23-748 (AN960-516) and up to a maximum of two off 126-23-749 (AN 960-516L) ie 3 washers maximum.

If end float of greater than 0.8mm is present, then 1 off only packing washer may be added at each pivot position as required, ie 126-23-105 M8 washer or 126-23-748 or 126-23-749 washers.

OCT 2002

Approved by: 	Date: 1 st Oct. 02.	Issue 4
For and on behalf of SLINGSBY AVIATION LIMITED	Page 1 of 7	
Kirkbymoorside, York. YO62 6EZ Fax No: 01751 431173	Tel: 01751 432474 E-mail: SAL5@Slingsby.co.uk	

If packing washers are required on the right hand rudder bar (T67M-45-259) then the packing washer (or the thicker washer if a thick and thin washer are required) should be placed at the outboard pivot.

Ensure maximum end float is not greater than 0.8mm and that brake cylinders are not subject to undue side load.

If clearance Ref 2 is achieved, annotate in Log Book "SB No.75 complied with". If not, proceed to paragraph 3.2.

3.2 Apply the following rudder set-up procedure:

- 3.2.1 Jack up front of aircraft until nosewheel is just clear of ground. Set aircraft level longitudinally and laterally.
- 3.2.2 Position rudder rigging board T67B-88-027 over fin.
- 3.2.3 Remove cowlings and disconnect steering rod from nosewheel.
- 3.2.4 Pedal assemblies all to be adjusted fully forward, ie for maximum leg length.
- 3.2.5 Disconnect turnbuckle barrel from both turnbuckle ends, see Fig. 2.
- 3.2.6 Re-assemble turnbuckle by simultaneously screwing onto ends ensuring equal engagement. Screw up until all of screw thread is into barrel, see Fig. 3.
- 3.2.7 Position straight edge T67G-88-501 across all four pedals (should all touch) check rudder neutral against rigging board.
- 3.2.8
 - i. If rigging board indicates rudder neutral:

Check movements ref Maintenance Manual and set stops, check for fouls.
 - ii. If movement achieved but pedals foul:

Tighten cables by screwing turnbuckle ends into barrel, as required. This effectively pulls pedal assemblies aft (towards tail).

Recheck rudder neutral, Ref. paragraph 3.2.7. If rudder not neutral, screw in relevant turnbuckle.
- 3.2.9 Set rudder movement with stops.
- 3.2.10 Check rudder movements to full extent: using foot loads verify all mechanical clearances, with pedals at all four pedal adjustment positions with and without brake applied. When satisfied, wirelock turnbuckles with double figure of eight wire configuration between clevis and diametric hole on turnbuckle barrel.
- 3.2.11 Reconnect steering arm with rudder neutral and nose wheel centred, adjusting steering arm fork end as required.
- 3.2.12 If clearance, ref paragraphs 1. and 2, is achieved, annotate in Log Book "SB No.75 complied with". If not, proceed to paragraph 3.3.

- 3.3 Modify pedal assy No.2, as follows:
 - 3.3.1 Remove No.2 pedal assy and modify as per Figure 4.

Note: Modify both square and round slider.
 - 3.3.2 No.2 pedal assy to be re-identified as T67G-03-851 and Mod M663. Annotate Mod M663 incorporated.
 - 3.3.3 If clearance, ref paragraphs 1. and 2, is achieved, annotate in Log Book "SB No.75 complied with". If not, proceed to paragraph 3.4.
- 3.4 Check heater box seating as follows, ref. Figure 5:
 - 3.4.1 Remove heater box and counter bore holes in accordance with Figure 5, Section A-A.
 - 3.4.2 Replace box and check seating. If box top flange fouls cleat cloth joining Frame 1 to Frame 2, then it is to be removed in accordance with Figure 5, Section B-B.
 - 3.4.3 Replace box. If clearance, ref paragraphs 1 and 2, is achieved, annotate in Log Book "SB No.75 complied with".
 - 3.4.4 If clearance is not achieved, then inform SAL.

SPACER T67M-45-507
OR
1 OFF 126-23-748
PLUS
1 OR 2 OFF 126-23-749
WASHERS MUST BE FITTED

END FLOAT 0.8 mm MAX

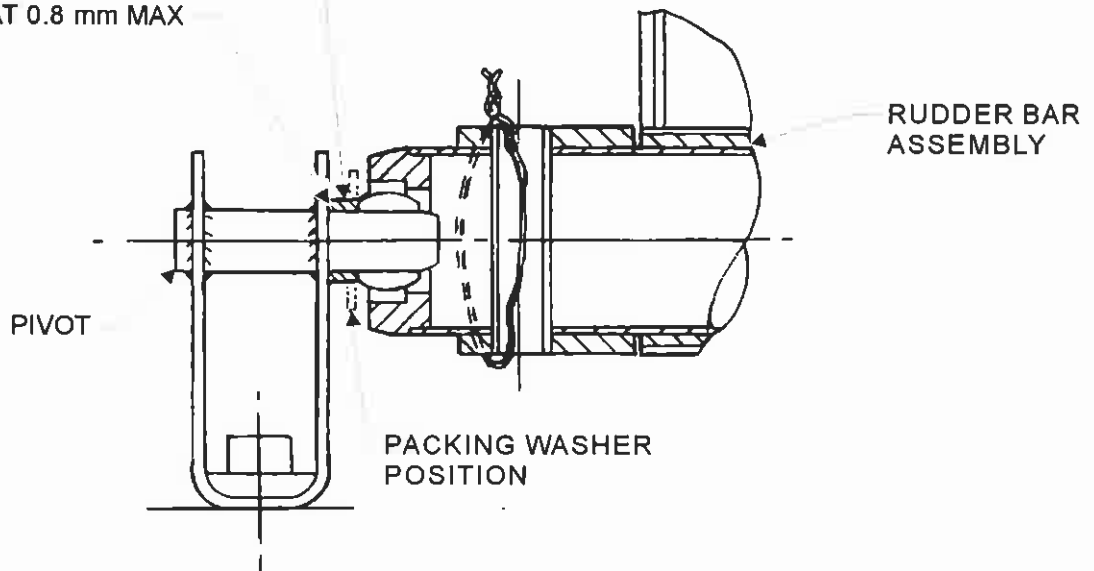

FIG 1

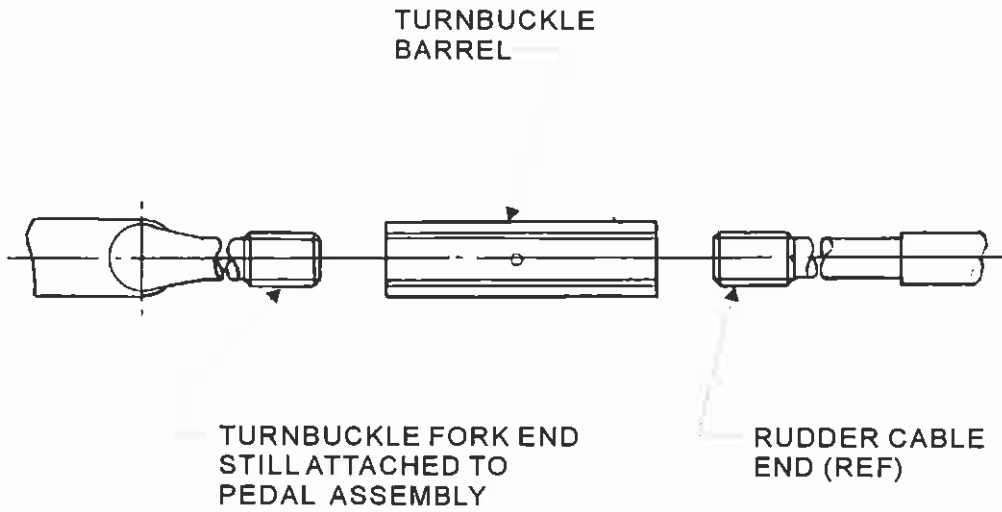

FIG 2

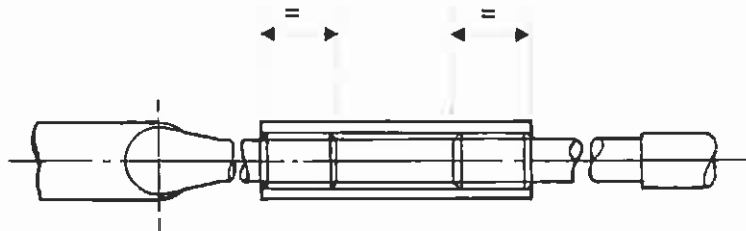
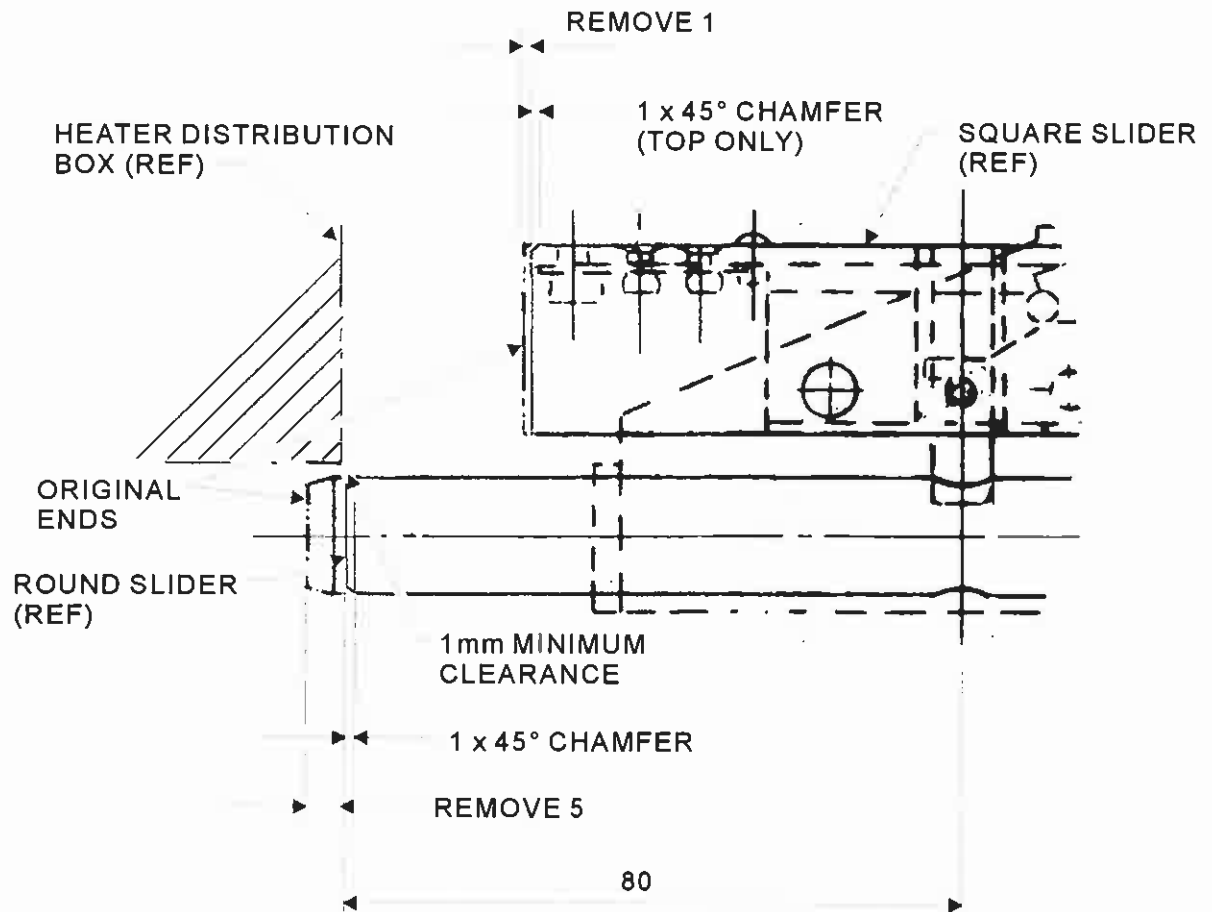

FIG 3



DIMENSIONS IN MILLIMETRES
 ETCH PRIME CUT ENDS

FIG 4

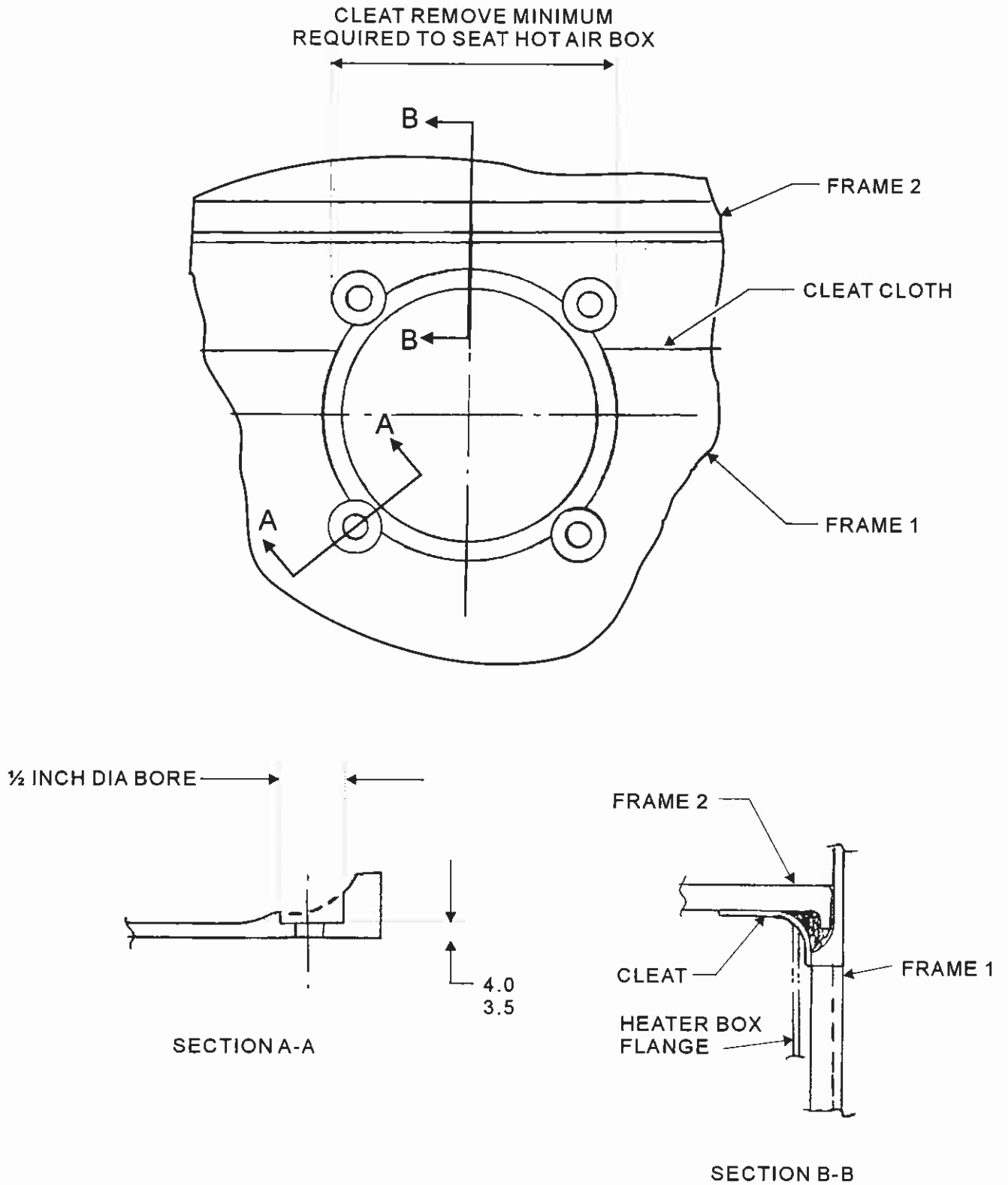

FIG 5