**SERVICE BULLETIN**

SB No. 039

Issue No. 1

**TITLE** INSPECTION OF WING REAR SPAR TOP SURFACE TO FUSELAGE FAIRING CLEARANCE**CLASSIFICATION** This Service Bulletin has been classified as optional by the U.K. Civil Aviation Authority.**COMPLIANCE** Within the next 150 flying hours, or 3 months from date of this Service Bulletin, whichever is earlier.**APPLICABILITY:**

All T67 GRP Series Aircraft, except Works Nos. 2074, 2077, 2081-2083, 2087, 2099-2101.

**INTRODUCTION:**

A case has occurred whereby the clearance between the wing rear spar top surface and the fuselage fairing has been insufficient to prevent contact at high positive load factors. This has resulted in cracking of the fuselage fairing which, although not structurally significant, is undesirable.

**ACTION:**

With the port and starboard, top surface, wing to fuselage rubber seal removed over an area from the wing trailing edge to just forward of the wing rear spar (520mm):

1. Inspect the fuselage fairing for cracking adjacent to the wing rear spar.
2. Measure and record the minimum clearance between the wing rear spar top surface and the fuselage fairing. (Port and starboard) (See Figure 1).
3. Pass details of 1, and 2, above to Slingsby Aviation Ltd.

Rectification action, if required, will be agreed between Slingsby Aviation Ltd and the Customer.

Annotate aircraft documentation "S.B. 039 Issue 1 accomplished".

**ISSUED**  
10 APR 1992

ISSUED BY:



Date

6<sup>th</sup> April 1992

for and on behalf of

SLINGSBY AVIATION LIMITED

Kirkbymoorside, York YO6 6EZ, England

Tel 0751 32474 Telex 57597

Page

1

of 2

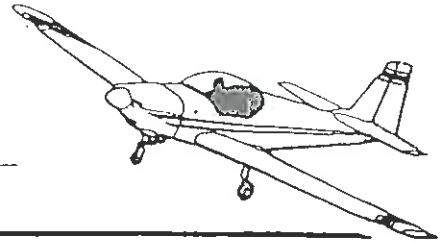

# SERVICE BULLETIN

SB No. 039

Issue No. 1

TITLE

INSPECTION OF WING REAR SPAR TOP SURFACE TO FUSELAGE FAIRING CLEARANCE

CONTINUED

POSSIBLE AREAS OF CRACKING IN FUSELAGE FAIRING

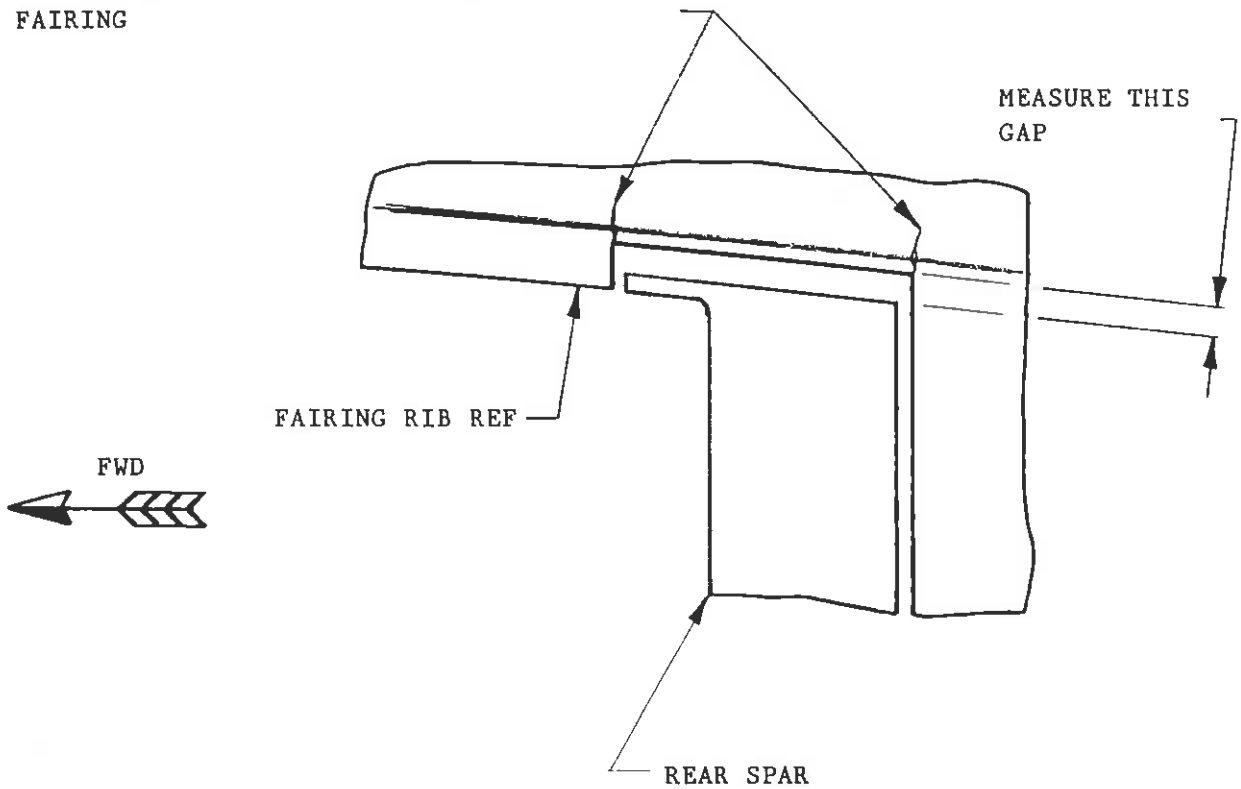

FIGURE 1

Approved:

*B. Mellen*

Date:

*6<sup>th</sup> April 1992*

Page

2

of

2